



P K PUMPS PVT.LTD.

AN ISO 9001-2008 COMPANY



MIXED FLOW NON - CLOG PUMPS -PKMF

P.K.PUMPS PVT .LTD

EST-1997

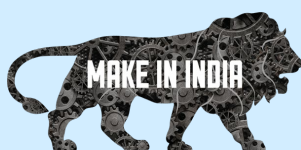

www.pkpumps.in

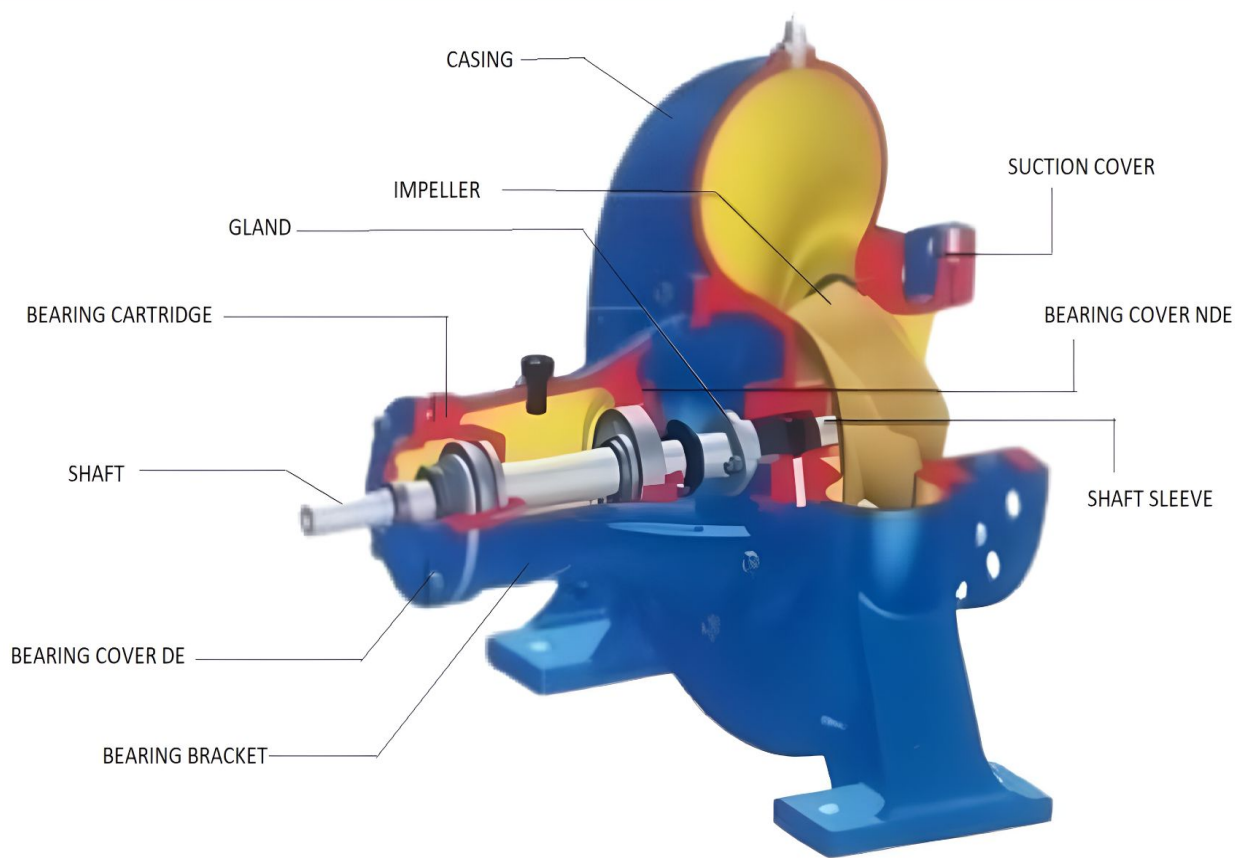

RANGE

Delivery size up to 650 mm
Capacity up to 7,000 m³/hr.

Head up to 30 m

APPLICATION

Pumping drainage water, storm water
Supplying water from settling tanks in water
works Irrigation and agriculture for lift
irrigation Circulation of hot or cold water in
industry
Air-conditioning plants
Power stations
Textile mills Sewage
handling Flood control



P K PUMPS PVT.LTD.

AN ISO 9001-2008 COMPANY

Description

Constructional Features

These are end suction single stage, horizontal shaft, volute type pumps. These pumps operate at 50 Hz and 60 Hz.

Casing

Horizontal/Vertical end suction high efficiency volute type with Top/side/45 degrees orientations. Delivery flange and supporting feet are cast integral with the casing.

Impellers

Non clog - Semi open / Enclosed type and balanced dynamically. Hydraulically balanced by balancing holes / back vanes.

Shaft

Made of high tensile steel, accurately grounded.
Supported by deep groove ball bearings and thrust bearing housed in the bearing housing.

Stuffing box

Gland packed supply is standard for liquids having temperature upto 90°C Mechanical seal, can be supplied against request.

Bearing

Deep groove ball bearing and thrust bearing. Standard lubrication - Oil (except MF 200 pump) MF 200 is with grease lubrication.

Direction of rotation

Clockwise viewed from driving end.

Drive

Suitable for coupling with electric motors, I.C. engines either directly or through belt drives/gear box.

Flanges

Flanges shall be drilled as per BSEN 1092, PN 16 flat face except MF 17 ½ - 20, MF 55-60, MF 60-65 pumps. For these models drilling will be BS 10 Table D



PK PUMPS PVT.LTD.

AN ISO 9001-2008 COMPANY

Cross - Section drawing of MF Pump

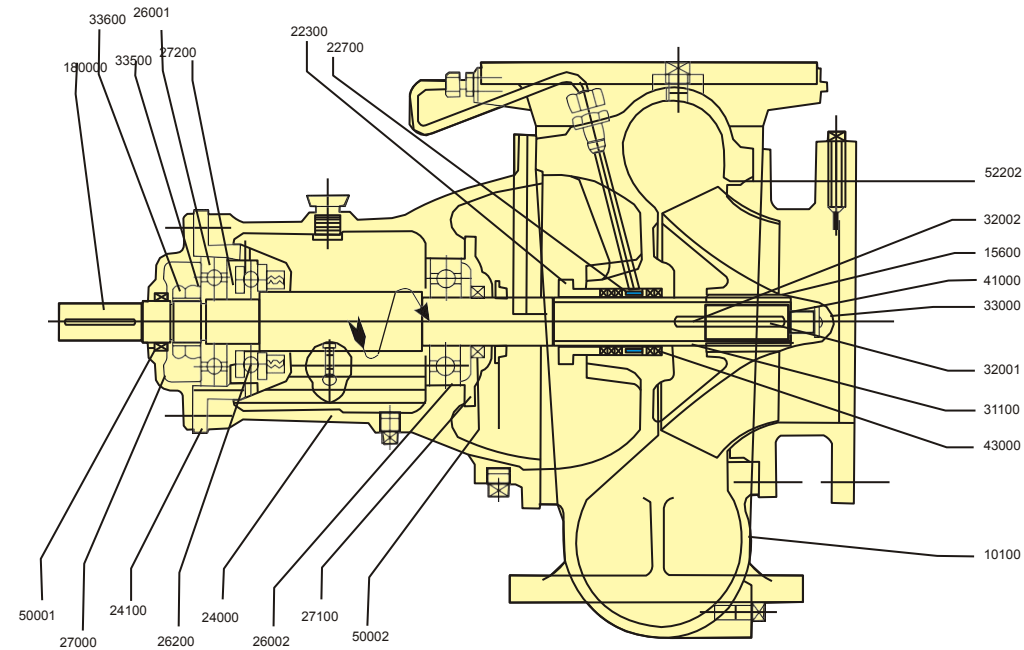

A) MF pumps are also available in Back pull out construction (MF-B)

B) MF pumps can be give with enclosed impeller (MF-E)

Material of Construction

Part	MOC 01	MOC 02	MOC 13	MOC 20	MOC 11	MOC 28	MOC 62	MOC 44	MOC 61
Pump Casing	CI	CI	CF8M	CI	CI	CI	CI	CI	NICI
Suction Cover	CI	CI	CF8M	CI	CI	CF8M	CI	CI	NICI
Impeller	CI	Br	CF8M	Br	CF8M	CF8M	CF8M	Br	CF8M
Pump shaft	40 C8	40 C8	SS 316	40 C8	40 C8	40 C8	SS 410	SS 410	SS 410
Shaft Sleeve	CI	Br	SS 316	CI	SS 316	SS 316	SS 316	Br	NICI
Lantern Ring	CI	CI	SS 316	CI	CI	CI	CI	CI	NICI
Gland CI	CI	CF8M	CI	CI		CI	CI	CI	NICI

NiCI indicates CI with 1.5% Nickel.

Other special materials, Please contact our regional office.

Material Standards

Material	IS	EQUIVALENT INTERNATIONAL STANDARDS	
		BS	ASTM
Cast Iron (CI) S. G. Iron (SGI)	IS 210 (1978) Gr. FG 200 IS 1865 (1974) Gr. SG 500/7	B.S.E.N. 1561-EN-GJL 200 B. S. 2789 SNG 500/7	ASTM-A 48 CL 25 ASTM-A 536 60-40-18 & 65-45-12
Austenitic Cast Iron (ACI) Carbon Steel (CS) CF8M AISI 316 (St. St.)	IS 2749 Gr. AFG Ni 15 Cu 6 Cr 3 IS 1570 Gr. 40CC 8 IS 3444 Gr. 9 IS 1570 Gr. 05 Cr 18 Ni 11 Mo 3	B.S. 3468 AUS 101 Gr.B B. S. 970 080 M 40 B.S. 1632 Gr. b B.S. 970 316 S16	ASTM-A 436 Type 1 ASTM-A 107 Gr. 1040 ASTM-A 351 Gr. CF8M ASTM-A 276 Type 316
AISI 304 (St. St.) AISI 410 (St. St.) Bronze Phosphor Bronze (Ph. Br.) Zinc Free Bronze (ZFB) Cast Steel	IS 318 Gr. LTB2 IS 28 Gr. 1	B.S. 970 304 S 15 B.S. 970 410 S 21 B.S.E.N. 1982 - CC 491K B.S.E.N. 1982 - CC 480K BS 1504-101A	ASTM-A 276 Type 304 ASTM-A 276 Type 410 ASTM-B62, B145 Alloy 4A ASTM-A 21674 d Gr. WCB

MIXED FLOW PUMPS - TYPE PKMF

INTERCHANGEABILITY CHART OF COMPONENT

PART NO./ PART CODE	Description	PUMP MODELS											
		NO.	DESCRIPTION	17-20	20-25	25-25	25-30	30-35	35-35	35-40	40-40	40-45	50-50
15600*	Impeller	1	2	3	4	5	6	6	7	7	8	9	10
18000	Shaft	1	1	2	2	3	3	3	4	4	5	5	6
24000	Bearing housing	1	1	2	2	3	3	3	4	4	5	5	6
24100	Cartridge	1	1	2	2	3	3	3	4	4	5	5	6
26001/26002*	Ball bearing DE and NDE	1	1	2	2	3	3	3	4	4	5	5	6
26200*	Thrust bearing	1	1	2	2	3	3	3	4	4	5	5	6
627000/27100	Bearing covers DE and NDE	1	1	2	2	3	3	3	4	4	5	5	6
50001/50002	Oil seal DE and NDE	1	1	2	2	3	3	3	4	4	5	5	6
31100	Shaft sleeve under stuffing box	1	1	2	2	3	3	3	4	4	5	5	6
22300*	Gland	1	1	2	2	3	3	3	4	4	5	5	6
22700*	Split lantern ring	1	1	2	2	3	3	3	4	4	5	5	6
27200	Thrust bearing adaptor	1	1	2	2	3	3	3	4	4	5	5	6
32001	Impeller Key	1	1	2	2	3	3	3	4	4	5	5	6
32002	Impeller and shaft sleeve key	1	1	2	2	3	3	3	4	4	5	5	6
33000*	Impeller nut	1	1	2	2	3	3	3	4	4	5	5	6
33500	Bearing nut	1	1	2	2	3	3	3	4	4	5	5	6
33101	Lock nut	1	1	2	2	3	3	3	4	4	5	5	6
43000*	Gland packing	1	1	2	2	3	3	3	4	4	5	5	6
52202*	O' ring for suction cover and pump casing	1	2	3	3	4	5	5	6	6	7	8	9
41000	Lock washer for impeller	1	1	2	2	3	3	3	4	4	5	5	6

PART NO./ PART CODE NO.	DESCRIPTION	PUMP MODELS											
		250	300	25-30A	30-35M	30-35M	35-35M	35-40M	50-50B	55-60E	30-35B		
15600	Impeller	11	12	13	14	15	16	17	18	19	5		
18000	Shaft	1	2	2	3	3	3	3	7	5	8		
24000	Bearing housing	1	2	2	3	3	3	3	7	5	8		
24100	Cartridge	1	2	2	3	3	3	3	7	5	8		
26001/26002	Ball bearing DE and NDE	1	2	2	3	3	3	3	7	5	8		
26200	Thrust bearing	1	2	2	3	3	3	3	7	5	8		
27000/27100	Bearing covers DE and NDE	1	2	2	3	3	3	3	7	5	8		
50001/50002	Oil seal DE and NDE	1	2	2	3	3	3	3	7	5	8		
31100	Shaft sleeve under stuffing box	1	2	2	3	3	3	3	7	5	8		
22300	Gland	1	2	2	3	3	3	3	7	5	8		
22700	Split lantern ring	1	2	2	3	3	3	3	7	5	8		
27200	Thrust bearing adaptor	1	2	2	3	3	3	3	7	5	8		
32001	Impeller Key	1	2	2	3	3	3	3	5	5	3		
32002	Impeller and shaft sleeve key	1	2	2	3	3	3	3	5	5	3		
33000	Impeller nut	1	2	2	3	3	3	3	5	5	3		
33500	Bearing nut	1	2	2	3	3	3	3	7	5	8		
33600	Lock nut	1	2	2	3	3	3	3	7	5	8		
43000	Gland packing	1	2	2	3	3	3	3	5	5	3		
52202	O' ring for suction cover and pump casing	1	3	3	4	4	5	5	7	8	4		
41000	Lock washer for impeller	1	2	2	3	3	3	3	5	5	3		

MIXED FLOW PUMPS - TYPE PKMF

General Dimensions / Mounting Details

VERTICAL DELIVERY END POSITION (MEGHA EXECUTION)

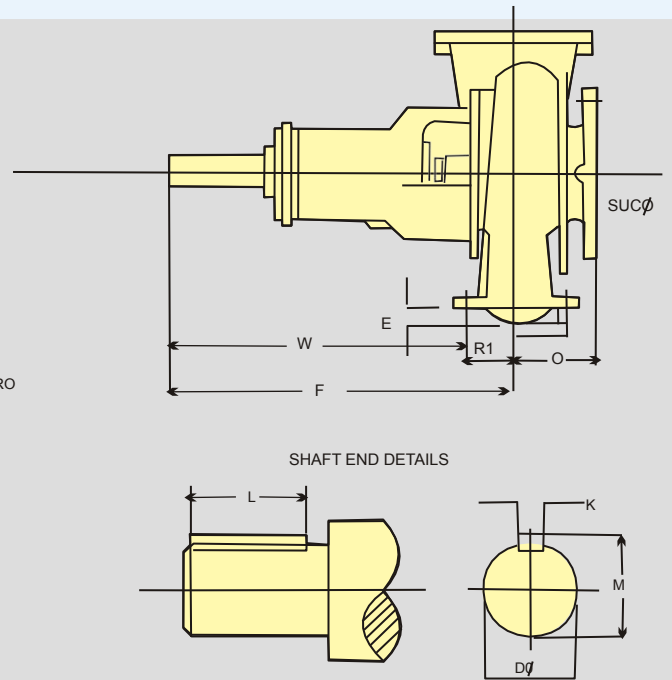
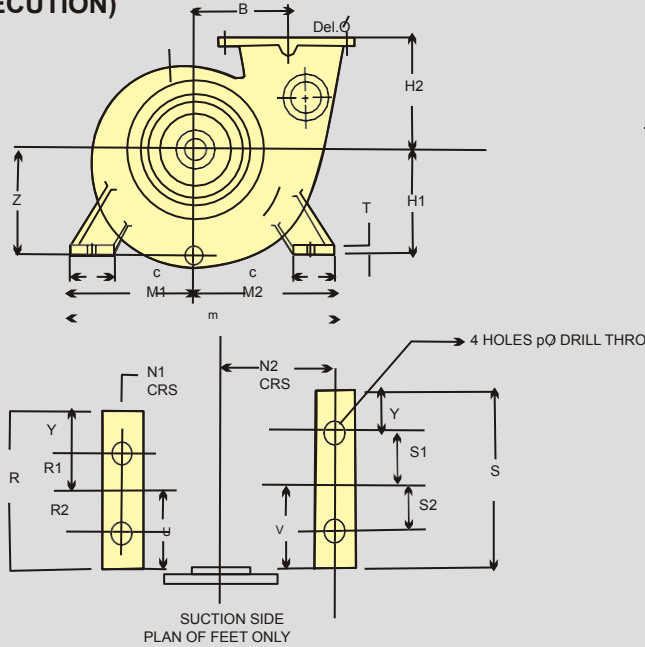

S R.	PUMP TYPE	PUMP MEASUREMENTS									
		SUC.	DEL.	a	f	j	e	h1	h2	z	b
1	MF 17 1/2 - 20 (AM 20A)	175	200	200	564	102	32	250	230	255	208
2	MF 20-25 (AM 25A)	200	250	215	545	120	40	280	275	290	240
3	MF 250	250	250	248	545	120	40	280	275	290	240
4	MF 25-25 (AM 25B)	250	250	245	620	145	31	315	285	315	268
5	MF 25-30 (AM 30A),A	250	300	245	620	145	50	355	320	370	300
6	MF 300	300	300	285	620	145	50	355	320	370	300
7	MF 30-35 (AM 35A)M1	300	350	295	707	161	85	400	370	435	355
8	MF 30-35 M	350	350	350	707	161	85	400	370	435	355
9	MF 35-35 (AM 35B),M	350	350	345	670	176	85	400	400	442	375
10	MF 35-40 (AM 40A),M	350	400	345	670	195	10	500	440	520	415
11	MF 40-40 (AM 40B)	400	400	390	872	182	85	470	450	515	428
12	MF 40-45 (AM 45A)	400	450	400	862	185	85	600	500	590	475
13	MF 50-50 (AM 50B)	500	500	490	960	212	140	600	625	648	535
14	MF 55-60 (AM 60A)	550	600	540	920	260	135	800	680	825	650
15	MF 55-60 E	600	600	540	920	260	135	800	680	825	650
16	MF 60-65 (AM 65A)	600	650	590	1047	297	214	800	850	890	710

S R. N O.	PUMP TYPE	FEET MEASUREMENTS															SHAFT END MEASUREMENTS							
		t	c	m1	m2	m	u	v	n1	n2	R1	R2	R	Y	S1	S2	S	PØ	W	DøM 6	M	K	L	Net weight In Kg (Approx
1	MF 17 1/2 - 20 (AM 20A)	24	110	270	320	590	140	140	215	265	90	110	260	30	110	110	280	7/8"	474	32	35.5	10	80	175
2	MF 20-25 (AM 25A)	26	120	310	360	670	155	155	250	300	100	120	290	35	120	120	310	1"	445	32	35.5	10	80	235
3	MF 250	26	120	310	360	670	155	155	250	300	100	120	290	35	120	120	310	1"	445	32	35.5	10	80	235
4	MF 25-25 (AM 25B)	28	130	330	390	720	175	175	265	325	95	125	320	50	125	1250	350	11/8"	525	42	45.5	12	110	325
5	MF 25-30 (AM 30A),A	32	140	385	450	835	190	190	315	380	120	140	360	50	140	140	380	11/8"	500	42	45.5	12	110	405
6	MF 300	32	140	385	450	835	190	190	315	380	120	140	360	50	140	140	380	11/8"	500	42	45.5	12	110	405
7	MF 30-35 (AM 35A)M1	36	170	470	550	1020	225	225	385	465	150	170	430	55	170	170	450	11/4"	557	50	54	14	120	535
8	MF 35-35 (AM 35B),M	36	170	470	550	1020	225	225	385	465	140	170	420	55	170	170	450	11/4"	30	50	54	14	120	550
9	MF 35-40 (AM 40A),M	40	200	530	620	1150	265	265	430	520	170	200	500	65	200	200	560	13/8"	500	50	54	14	120	720
10	MF 40-40 (AM 40B)	56	196	663	733	1396	280	280	565	635	170	210	520	70	210	210	560	13/8"	702	70	76	20	170	1150
11	MF 40-45 (AM 45A)	60	200	625	700	1325	315	300	525	600	225	255	600	60	240	240	600	13/8"	637	70	76	20	170	1375

MIXED FLOW PUMPS - TYPE PKMF

MF - 200 Pump

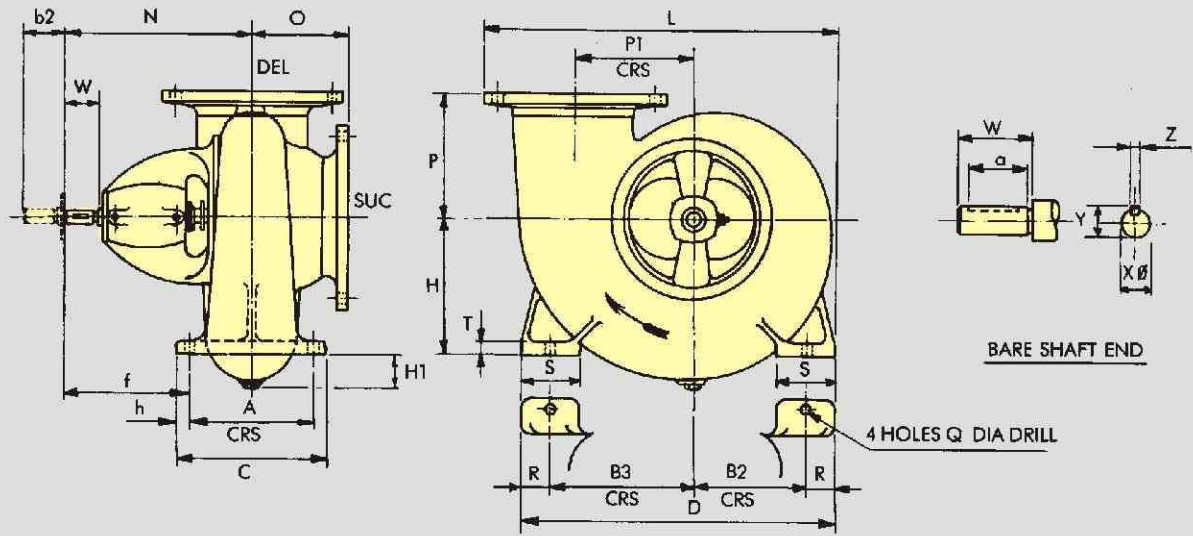

PUMP MODEL	SUC	DEL	A	a	h	B2	B3	C	D	f	H	H1	h	L	N	O	P	P1	Q	R	S	T	W	Xf	Y	Z	b2	W T K G
MF 200	200	200	220	55	30	215	265	280	590	260	250	70	30	661	370	180	230	220	23	55	110	24	68	32	35.5	10	150	120

Cross Sectional View MF-200 Pump

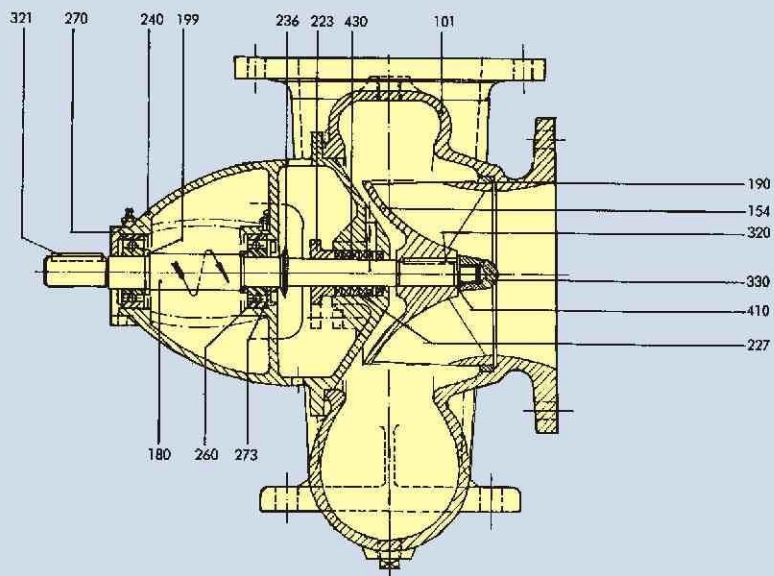

PART NO.	NAME OF THE PART	PART NO.	NAME OF THE PART
101	PUMP CASING	260	BEARING
154	IMPELLER	270	BEARING COVER
180	SHAFT	273	BEARING END CAP
190	WEAR RING	320	IMPELLER KEY
199	SHOULDER RING	321	COUPLING KEY
223	GLAND	330	IMPELLER NUT
227	LANTERN RING	410	LOCK WASHER
236	DEFLECTOR	430	GLAND PACKING
240	BEARING HOUSING		

MIXED FLOW PUMPS - TYPE PKMF

Family Curve of MF Pump at rated rpm - 50 Hz

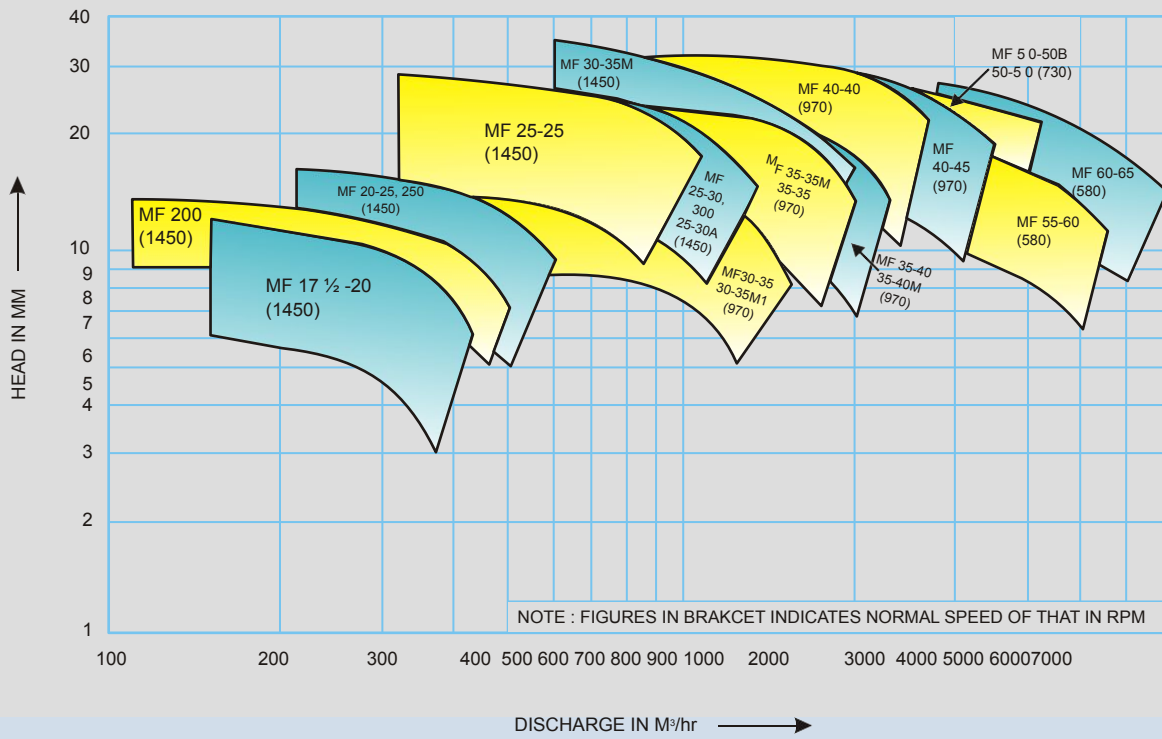

Family Curve of MF Pump at rated rpm - 60 Hz

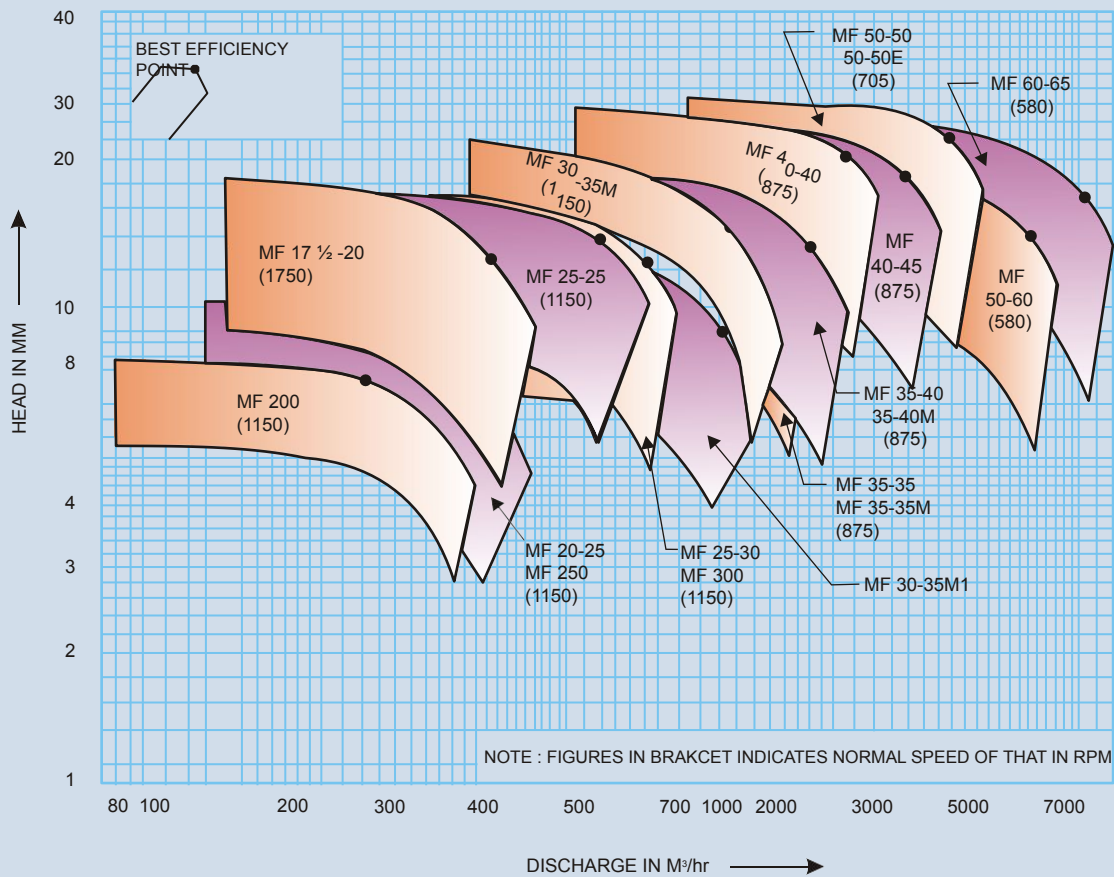



As we are constantly endeavouring to improve the performance of our products/ equipment, we reserve the right to make alterations from time to time and as such our products/ equipment may differ from that detailed in this publication. For latest information you may get in touch with our Regional Sales Offices.



P K PUMPS PVT.LTD.

AN ISO 9001-2008 COMPANY

**Address: P.K.PUMPS AND PRECICAST PVT LTD, PLOT S40/1,
BEHIND DIAMOND GRANITE, MIDC KUPWAD, SANGLI,
MAHARASHTRA, INDIA**

Phone: +91-9422407840, +91-9175030202, +91-9890151449

Email: pkpumps@rediffmail.com

Web: www.pkpumps.in

